

MC 115 B

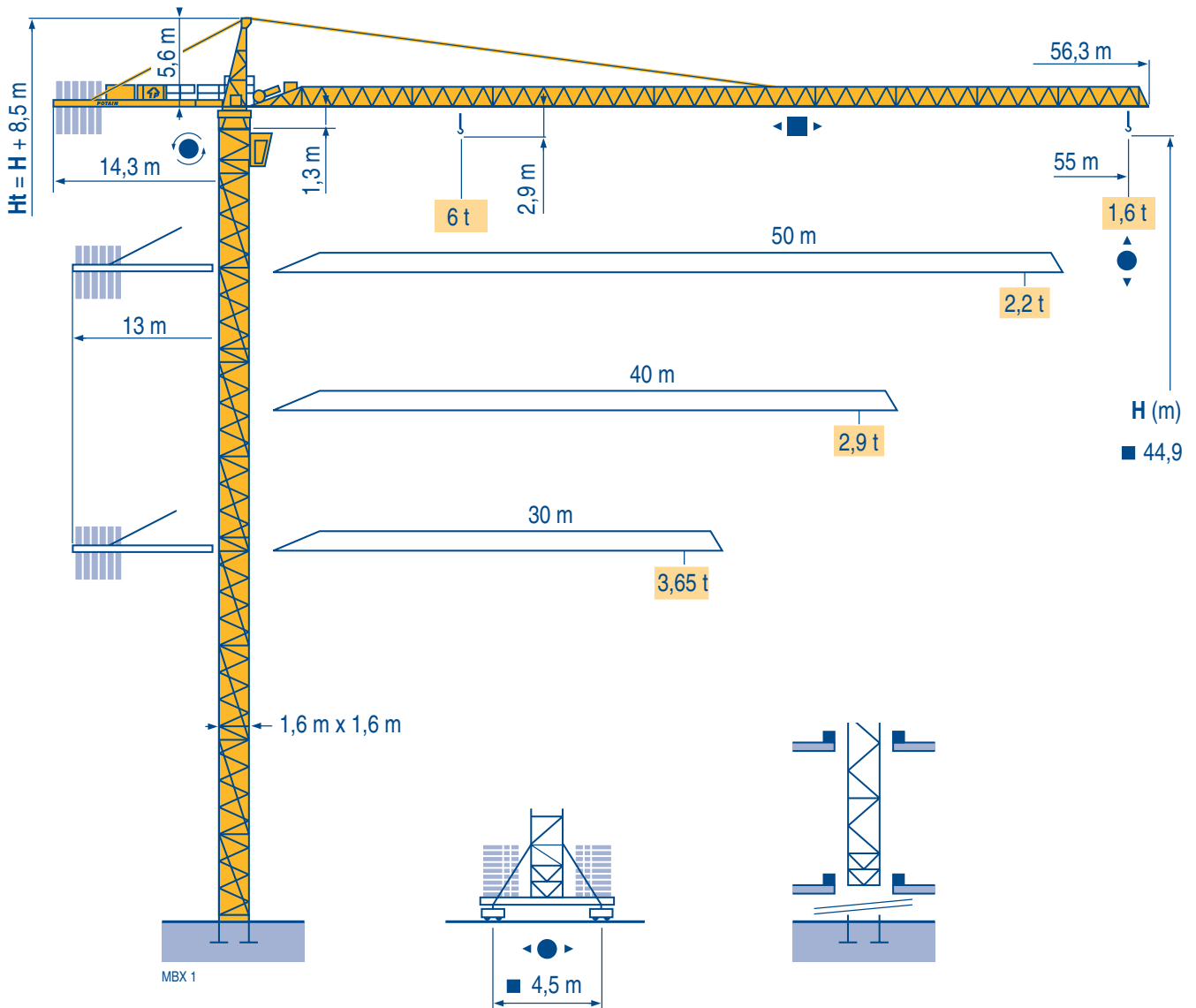

CITY CRANE

Masts / Reactions

□ 1,6 m
 ▧ 30 m → 55 m

MBX 1

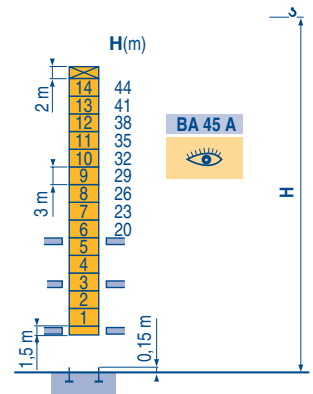
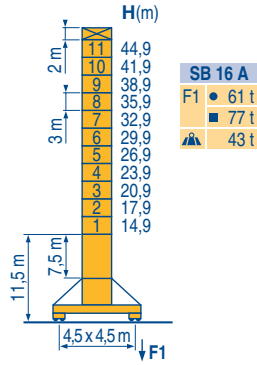
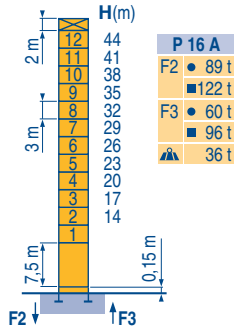

Climbing crane

MBX 1

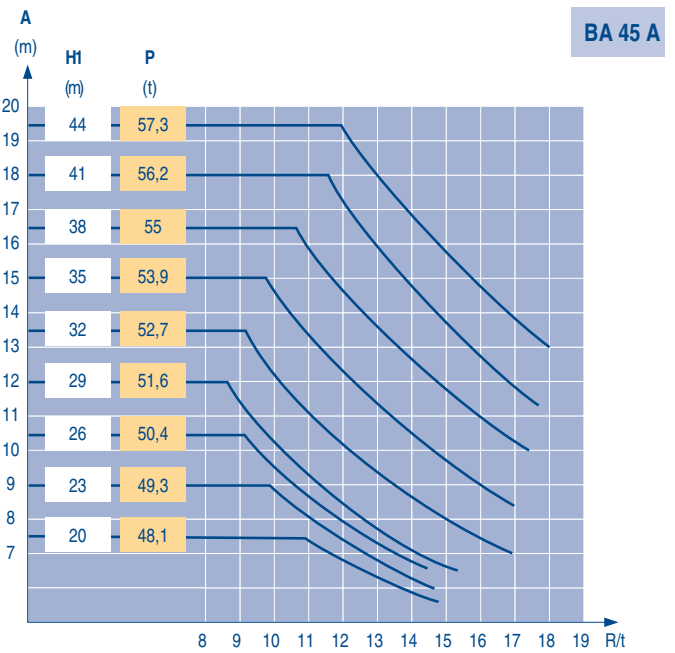
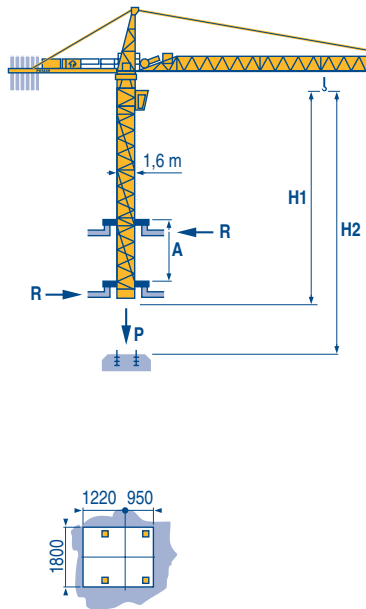

CITY CRANE
MC 115 B



GB

- Reactions in service
- Reactions out of service
- 👤 Without load, ballast (or transport axles), with maximum jib and maximum height.
- 👁 See climbing crane

Load diagrams

MBX 1

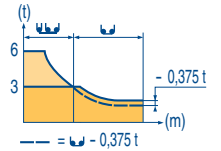
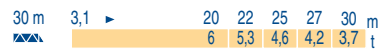
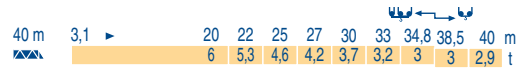
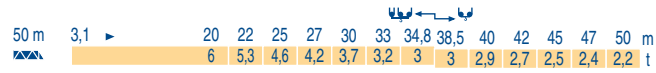
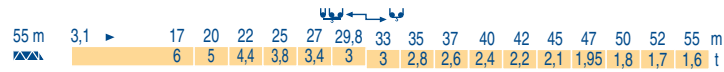

Counter-jib ballast

MBX 1

			3450 kg	2250 kg	(kg)
55 m	14,3 m	3	1	16 050	
50 m	13 m	3	1	16 050	
40 m	13 m	4	-	13 800	
30 m	13 m	2	2	11 400	

Base ballast

MBX 1

□ 1,6 m	SB 16 A	H (m)											
		44,9	41,9	38,9	35,9	32,9	29,9	26,9	23,9	20,9	17,9	14,9	
		▲ (t)											
		66	54	42	42	42	42	42	42	42	42	42	42

Anchorage

MBX 1

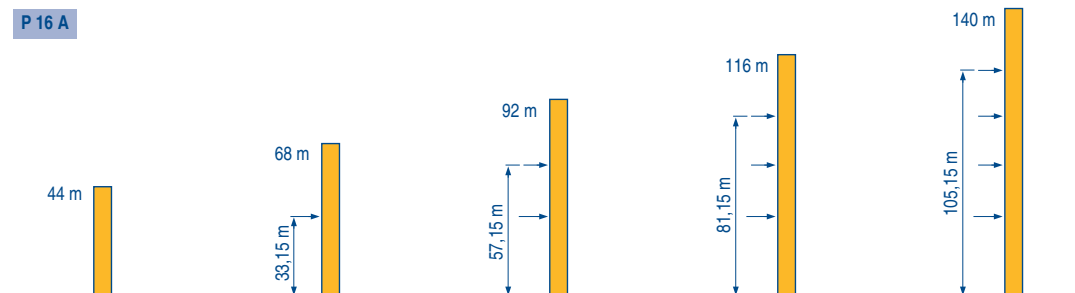

CITY CRANE MC 115 B

POTAIN

GB

- A** Distance between collars
- H1** Crane height
- P** Crane weight (in service)
- R** Horizontal reaction

Mechanisms

MBX 1

								hp	kW		
	33 PC 15	m/min	6,2	38	76	3,1	19	38	33	24	320 m
		t	3	3	1,5	6	6	3			
	4 D3 V3	m/min	15 - 30 - 58						4	3	
	RCV 145	rpm	0 → 0,8						2 x 6	2 x 4,4	
	SB 16 A RT 324 R ≥ 10 m	m/min	12,5 → 25						2 x 7	2 x 5,2	
CEI 38		IEC 38		kVA							
400 V (+6% -10%) 50 Hz		33 PC : 50 kVA				2000/14					

GB

- Hoisting
- Trolleying
- Slewing
- Travelling
- In compliance with the EEC Instructions on noise level



This commercial document is not legally binding.
For any technical information, please refer to the corresponding instructions.

Manitowoc
Crane CARE

Manitowoc
Crane Group



Manitowoc Crane Group Asia Pte Ltd
Manitowoc Crane Group
26 Benoi Road
Singapore 629898
Tel: 65-6861 7133
Fax: (Admin/ Sales) : 65-6862 4040
Fax: (Service/ Parts) : 65-6862 4142
www.manitowoccrane.com

Americas
Tel: +1 920 683 6322
Tel: +1 717 597 8121

Europe - Middle East - Africa
Tel: +(33) 4 72 81 50 00
Tel: +(44) 191 565 6281

Asia - Pacific
Tel: +(65) 6861 7133
Fax: +(65) 6862 4142

www.manitowoccrane.com

CITY CRANE MC 115 B

Réf. 2004 45 MBX 1

Copyright.Reproduction interdite © POTAIN 2004

Réalisation Sedoc